

Single Point type Load Cells

Model: CZL601AC

CAPACITY:

50kg,100kg,120kg,150kg,200kg

FEATURES:

Designed for off-center load , Maximum platform size :250x250 mm (according to capacity) ,Small sized ,Material : anodized aluminium alloy - Protection: IP 65

Easy to install,Economical and high accuracy.

APPLICATIONS:

Bench scales,Small hopper weighing,Filling, packaging and batching

Drawing:(mm)

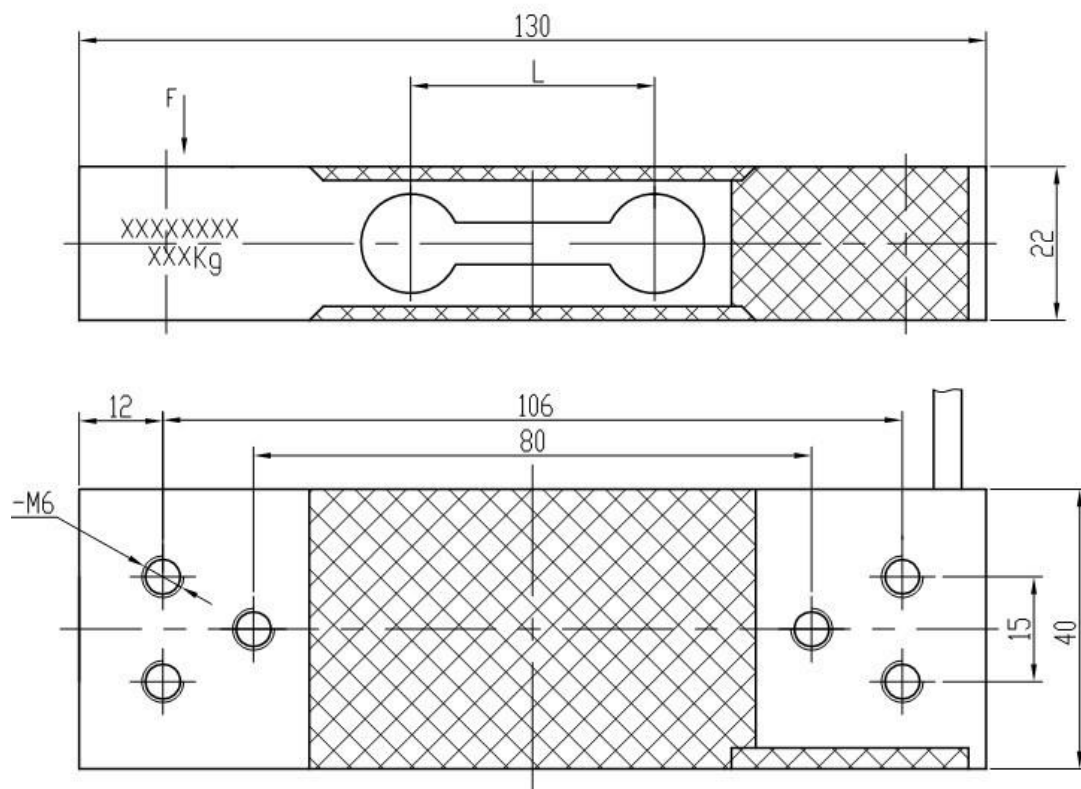

Parameters:

Precision:	C2
Ful Scale Output:	2mv/v±0.1
Creep(%F.S/30min):	±0.02
Zero balance(%F.S):	±1.0
Input resistance:	405±10
Output resistance:	350±3
Insulation resistance:	≥5000(100VDC)
Temp. effect on span(%F.S/10°C):	±0.02
Temp. effect on zero(%F.S/10°C):	±0.02
Use temp. range(°C):	-20 ~ +55
Excitation voltage(V) : :	9~12(DC)
Safety overload (%F.S)	150%
Defend grade	IP65
Cable Length:	0.45meters -3 meters
Connection:	Red (Input+), Black(Input-), Green(Output+), White(Output-)